

# Running Engine Stand

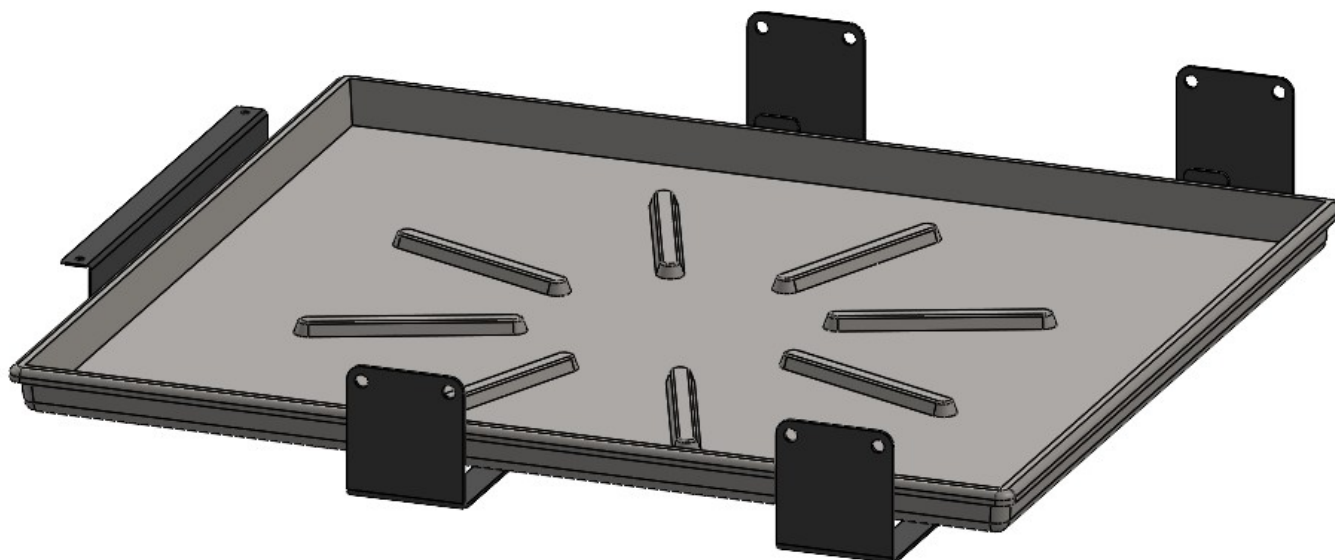

## Drip Pan Assembly Instruction Manual

## Important Notes for Assembly:

- This manual is for the Drip Pan add-on of the Running Engine Stand assembly. If you have not yet started with the Main Assembly instructions, start there before returning here.
- Use care when handling parts. There may be sharp edges and holes on components. Using thick protective gloves is recommended during the assembly process.
- Each bolt and nut should have the appropriately sized washer placed between the fastener and the frame.

### Required Tools:

- Ratchet
- 7/16" Wrench
- 7/16" Socket
- 5/8" Wrench
- 5/8" Socket

**If you are experiencing problems upon installation—  
DO NOT RETURN THIS PRODUCT!**

**Most installation problems can be easily solved.**

First contact technical support at:



**Service@mechman.com**

**1 (888) MECHMAN or 865-522-6166**

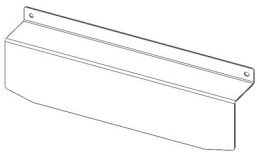
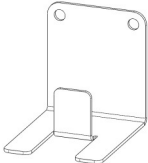
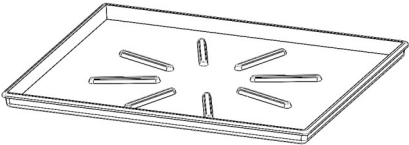
# Included Components:

	Front Drip Pan Bracket	1x
	Side Drip Pan Bracket	4x
	Drip Pan	1x

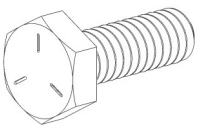
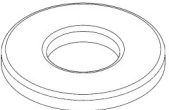
# Included Hardware

	1/4"-20 x 0.75" Hex Bolt	2x
	1/4" Flat Washer	4x
	1/4"-20 Nylock Nut	2x

# Assembly Instructions:

## Step 1: Attaching the Side Drip Pan Brackets to the Assembly

Required Components:

- 4x Side Drip Pan Brackets
- **Note: This step uses hardware from Step 1 and 2 of the Main Assembly instructions and should be completed simultaneously. If these steps are already complete, remove the necessary hardware and reinstall with the added bracket in place.**
- Use the fasteners for the crossmembers from Steps 1 & 2 of the Main Assembly instructions to attach the Side Drip Pan Brackets to the Assembly.

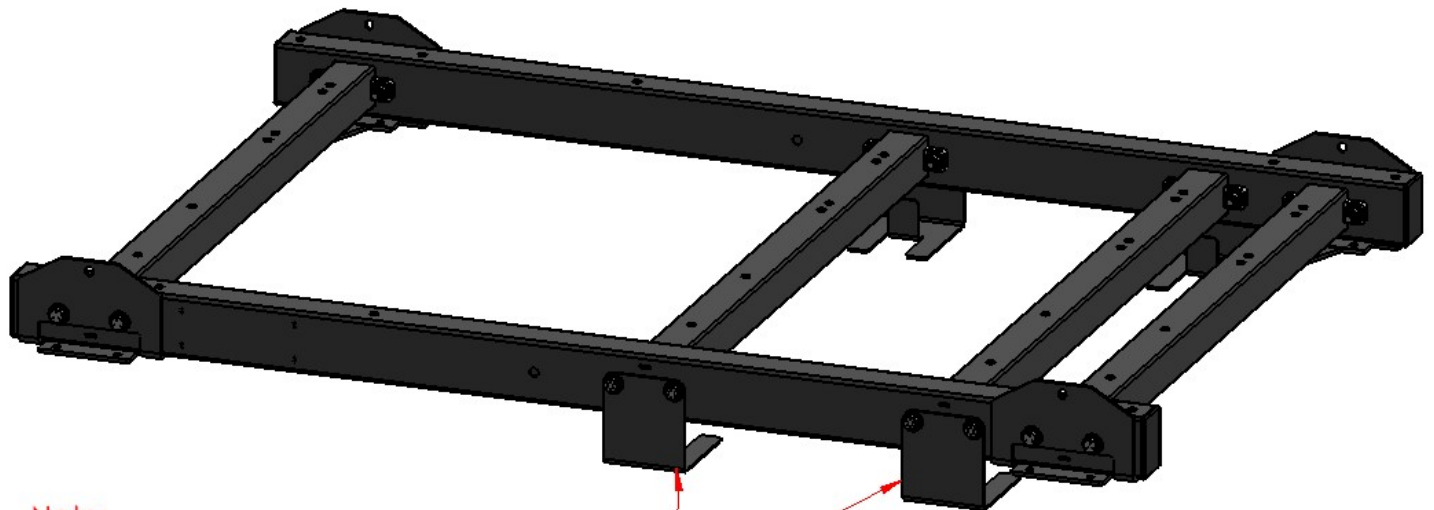

Note:  
Install 4x Side Drip Pan Brackets during  
Step 1 & 2 of Main Assembly instructions

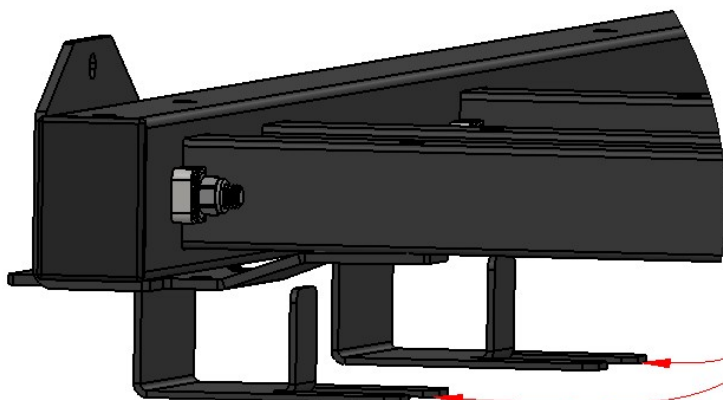

Note:  
Flanges of the Side Drip Pan  
Brackets should point towards  
the center of the assembly

# Assembly Instructions:

## Step 2: Attaching the Front Drip Pan Bracket to the Fuel & Battery Tray

### Required Components:

- 1x Front Drip Pan Bracket

### Required Hardware:

- 2x 1/4"-20 x 0.75" Hex Bolt
- 4x 1/4" Flat Washer
- 2x 1/4"-20 Nylock Nut

- After installing the Fuel and Battery Tray, attach the Front Drip Pan Bracket using the 1/4"-20 x 0.75" Hex Bolts.

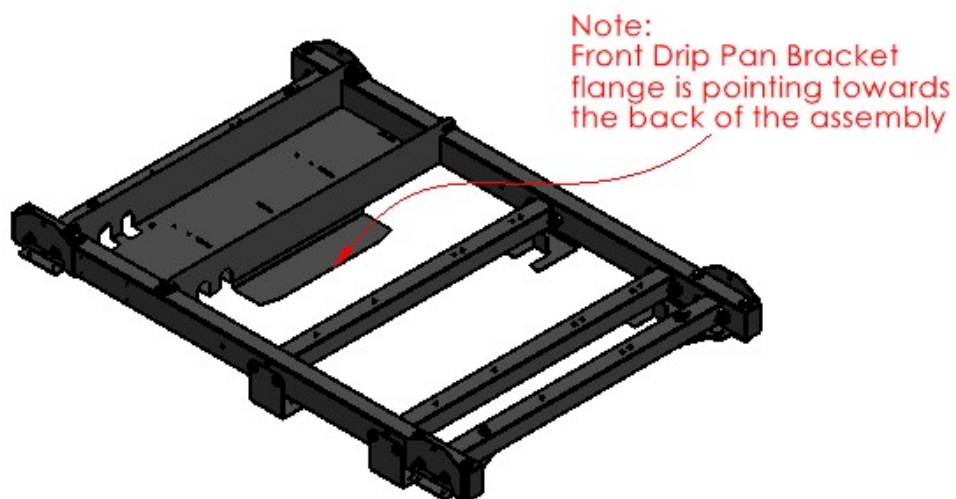
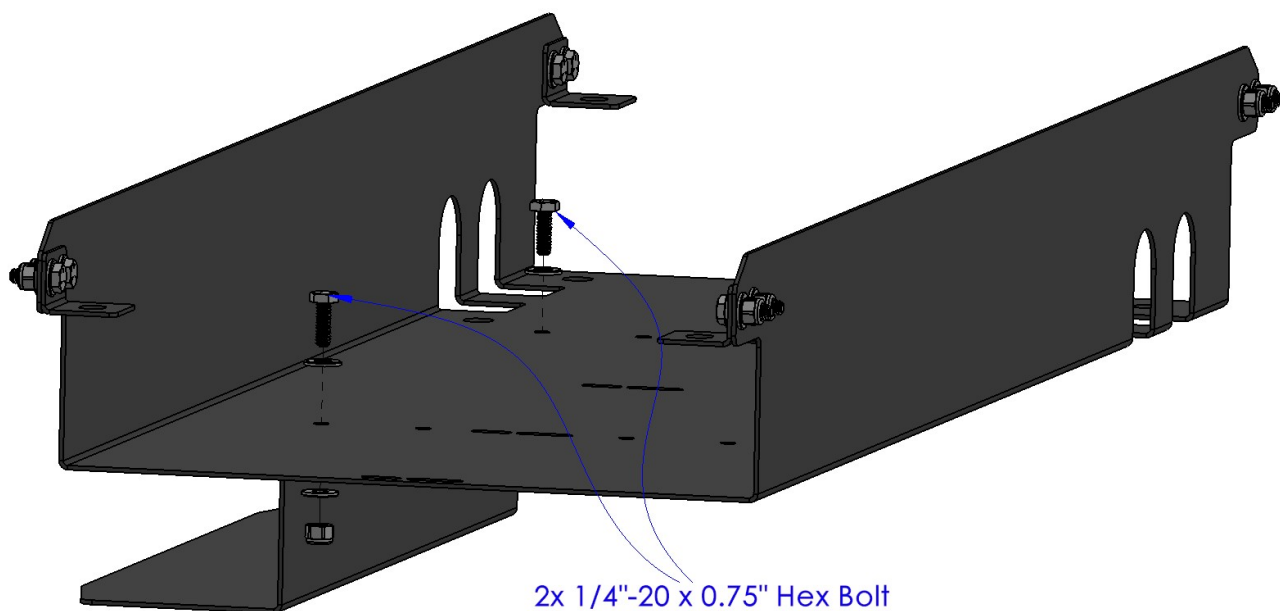

# Assembly Instructions:

## Step 3: Sliding the Drip Pan into the Assembly

Required Components:

- 1x Drip Pan
- Slide the Drip Pan onto the Side Drip Pan Brackets until it hits the back of the Front Drip Pan Bracket.

